

Portable Filter Carts

Models 5MF and 10MF



Global Filtration Technology

5MF and 10MF

Portable Filter Cart

Applications for Parker Filter Carts

- Filtering new fluid before putting into service
- Transferring fluid from drums or storage tanks to system reservoirs
- Conditioning fluid that is already in use
- Complimenting existing system filtration
- Removing free water from a system
- For use with fluids such as hydraulic, gear and lube oils

Parker filter carts are the ideal way to prefilter and transfer fluids into reservoirs or to clean up existing systems.

Fluid should always be filtered before being put into use. New fluid is not necessarily clean fluid. Most new fluids (right out of the drum) are unfit for use due to high initial contamination levels. Contamination, both particulate and water, may be added to a new fluid during processing, mixing, handling and storage.

Water is removed by installing Par-Gel™ elements in the outlet filter. Par-Gel™ elements are made from a polymer which has an

extremely high affinity for free water. Once water comes into contact with this material, it is removed from the system.

The Parker filter cart uses *two* high capacity ModuFlow™ filters for long element life and better system protection. The first stage (inlet) filter captures larger particles, while the second stage (outlet) filter controls finer particles or removes water. A rugged industrial quality gear pump gets the job done fast.

Using a Parker portable filter cart is the most economical way to protect your system from the harm that can be caused by contamination.

Features	Advantages	Benefits
<ul style="list-style-type: none"> • Two filters instead of one. 	<ul style="list-style-type: none"> • Pump protection and long element life. 	<ul style="list-style-type: none"> • Element cost savings and trouble-free service.
<ul style="list-style-type: none"> • Wide variety of particulate elements available. 	<ul style="list-style-type: none"> • Capable of getting a fluid to a desired cleanliness level. 	<ul style="list-style-type: none"> • Avoids excess costs due filter to over or under filtration.
<ul style="list-style-type: none"> • Par-Gel water removal elements available. 	<ul style="list-style-type: none"> • Removes “free water” from a system. 	<ul style="list-style-type: none"> • Gets dirt and water out of system with one process.
<ul style="list-style-type: none"> • Heavy duty frame. 	<ul style="list-style-type: none"> • Rugged and durable. 	<ul style="list-style-type: none"> • Built to last for many hours of use.
<ul style="list-style-type: none"> • Lightweight and portable. 	<ul style="list-style-type: none"> • Easy to move from place-to-place. 	<ul style="list-style-type: none"> • One person operation.
<ul style="list-style-type: none"> • Two flow rates available (5 gpm or 10 gpm). 	<ul style="list-style-type: none"> • Enables use in low or high viscosity applications. 	<ul style="list-style-type: none"> • Matched to your needs.
<ul style="list-style-type: none"> • Eleven-foot hose and wand assemblies included. 	<ul style="list-style-type: none"> • Additional hardware not necessary. 	<ul style="list-style-type: none"> • Ready to use as received.

Features

Service Cover

- Top-accessible for easy changing of elements

Dual Filters

- Two-stage filtration for long element life and pump protection

Hose & Wand Assembly

- Ready to use; no additional hardware needed
- Flexible hoses for tight spots
- Kink-resistant hose prevents pump cavitation

Gear Pump

- Industrial quality
- Quiet operation
- Dependable, long life

Visual Indicator

- Tells you when to change elements

Motor

- Industrial brand name

Heavy Duty Frame

- Rugged and built to last

Drip Pan

- Helps keep the work area safe and clean

Elements (not shown)

- Available for both particulate and water removal

Electrical Cord (not shown)

- 6ft. with on/off switch
- Optional 20 ft. cord with reel

5MF and 10MF

Portable Filter Cart

Specifications

Maximum Recommended Fluid Viscosity:

10MF: 500 SUS (108 cSt) (.85 specific gravity)

5MF: 3000 SUS (627 cSt) (.85 specific gravity)

Visual Indicator:

Visual differential type

3-band (clean, change, bypass)

Filter Bypass Valve Settings:

Inlet: 3 psid (.2 bar)

Outlet: 25 psid (1.7 bar)

Operating Temperatures:

Buna N (Nitrile) -40°F to 150°F
(-40°C to 66°C)

F3 (high temp option)
-15°F to 200°F
(-26°C to 93°C)

Electrical Service Required:

115 volts, 10 amps, single phase, 60 Hz

Electrical Motor:

10MF - ¾ hp @ 3450 rpm, O.D.P.

5MF - ½ hp @ 1725 rpm, O.D.P.

Thermal overload protection

Construction:

Cart Frame: Steel

Filter Head: Aluminum

Filter Bowl: Steel

Hoses: PVC (Std.)

EDPM (high temp option)

Wands: PVC (Std.)

Steel tube (high temp option)

Weight (approximate): 110 Lbs. (45.4 kg)

Dimensions: inches (millimeter)

A - Height: 40.5" (1029)

B - Width: 25.5" (648)

C - Depth: 19.0" (483)

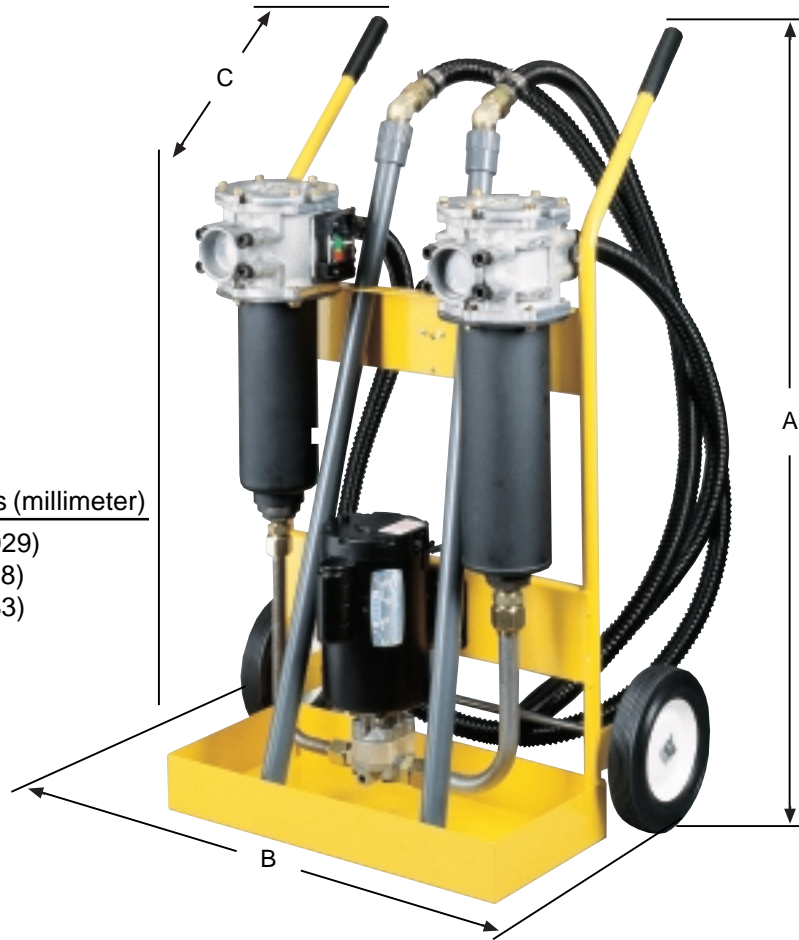

Typical Fluid Cleanliness Level Requirements

Many manufacturers of hydraulic components have established fluid cleanliness levels for their components. Using a portable filter cart can be a very effective way to reach and maintain these cleanliness levels.

Component	ISO Cleanliness Level
Servo control valves	16/14/11
Proportional valves	17/15/12
Vane and piston pumps/motors	18/16/13
Directional and pressure control valves	18/16/13
Gear pumps/motors	19/17/14
Flow control valves cylinders	20/18/15
New fluid	20/18/15

Filter Cart Performance

Fluid cleanliness levels are a function of initial contamination levels, contamination ingress rates, reservoir size and filter element efficiency. The chart below lists approximate time requirements to achieve certain cleanliness levels based on the assumptions noted.

Reservoir Capacity (Gallons)	Time Required (Hours)	Projected Cleanliness Level (ISO)
50	0.5	20/18/15
50	1.0	17/15/12
50	2.5	16/14/11
100	1.5	18/16/13
100	2.5	17/15/12
100	4.0	16/14/11
200	2.5	19/17/14
200	3.5	18/16/13
200	5.0	17/15/12

- Notes:** The results in the chart are based on the following assumption:
1. Initial contamination level is 500,000 particles greater than 10 micrometers per 100 ml of fluid (10MF cart).
 2. Inlet filter fitted with 40SA element. outlet with 10C element.
 3. System ingress rate equal to 1×10^6 particles greater than 10 micrometers entering the system per minute.

Filter Cart Element Performance

Media Code	Filter Media	Time Averaged Beta x/y/z =2/20/75 Where x/y/z is:	Capacity (Grams)	Beta Rating	Efficiency at x,y,z Particle Size
74W	Woven Wire	0.0029 ¹	*	Bx = 2	50.0%
40W	Woven Wire	0.0016 ¹	*	By = 20	95.0%
40SA	Synthetic	40 Micron Nominal ²	*	Bz = 75	98.7%
20C	Cellulose	20 Micron Nominal ²	*		
10C	Cellulose	6/18/22 Micron	15		
03C	Cellulose	2/6/9 Micron	18		
20Q	Microglass II	7.5/12.5/17 Micron	47		
10Q	Microglass II	<2/6/9 Micron	42		
05Q	Microglass II	<2/<2/3.3 Micron	46		
02Q	Microglass II	<2/<2/2 Micron	45		

- Notes:** Multipass test run @ 40 gpm to 25 psid.
ANSI/NFPA T3.10/8.8 R1-1990 w/50 ppm anti-static additive
*Not Applicable.
1. Not multipass tested- Number shown is actual pore size in inches.
 2. Not multipass tested.

Par-Gel™ Media Water Capacity

Model	Fluid Viscosity	Capacity
5MF	75 SUS	250 ml
	200 SUS	140 ml
10MF	75 SUS	190 ml
	200 SUS	80 ml

- Notes:**
1. Par-Gel elements are designed to remove "free water", which is defined as water that is above a particular fluid's saturation level.
 2. Capacity is very dependent on flow rate and viscosity. Not recommended with fluids in excess of 500 SUS.

5MF and 10MF

Portable Filter Cart

Assembly

1) Install hoses to inlet and outlet filters by threading the hose end with the straight thread “o”-ring seal fitting into the filter flange.

2) Connect the PVC tube wands to the swivel fitting on the hose end.

Whenever servicing the PVC tube wand *do not overtorque* the metal fittings going into the PVC coupling. Overtorque will result in cracking the coupling. Generally, 1/4 turn beyond handtight is sufficient.

Operating Instructions

1) Insert the inlet wand assembly into the supply fluid receptacle (drum/reservoir). The “RF” filter is the inlet filter.

2) Insert the outlet wand assembly into the clean fluid receptacle (drum/reservoir). The “CF” filter is the outlet filter.

Caution:

Do not kink the hose assemblies, this may result in excessive vacuum or pressure at the pump.

3) Verify that the ON/OFF switch is OFF and plug the cord into a 115V 10A grounded outlet (3 wire).

4) Turn switch to ON position and check outlet wand for oil flow. Allow 30 to 60 seconds for filters to fill with oil. If repeated attempts to obtain oil flow fail, check pump inlet fittings for tightness, remove inlet filter access cover and verify the cover sealing “o”-ring is in place. For very viscous fluids it may be necessary to pour 1 or 2 quarts of fluid into the “RF” inlet filter housing to prime pump initially.

5) The condition of the filter element should be monitored by observing the cleanliness indicator on the discharge filter. When the Indicator is in the CHANGE position, both inlet and outlet filter elements MUST be replaced to prevent fluid from going into bypass in the filters.

6) The inlet filter is provided with a 3PSI bypass spring, and prevents the pump from cavitating. If the element is not changed. The outlet filter is provided with a 25PSI bypass spring to prevent excessive pressure which may be harmful to personnel or to the filter cart.

Warning:

The filter bypass spring acts as a relief valve for the pump. Do not restrict the discharge hose with a shut-off valve which will defeat the function of the bypass valve, causing excessive pressure, which may be harmful to personnel or to the filter cart.

7) The cleanliness indicator works on differential pressure and will indicate the condition of the element (CLEAN, CHANGE, or BYPASS).

NOTE:

The filter cart must be in operation for the indicator to read properly.

Maintenance Instructions

1) Turn switch to OFF position and unplug cord from electrical outlet.

2) Remove tube wands from oil to prevent siphoning.

3) Loosen hex head screws on filter cover. Turn cover to clear screws, remove cover.

4) Pull flow diverter assembly from the filter head. Filter element will follow the diverter.

a) Replace the cellulose, synthetic or Microglass II elements. Verify replacement.

b) Wire mesh elements can be cleaned. Ultrasonic cleaners provide best results.

5) Install element on flow diverter and reinstall in filter housing. Make sure diverter “o”-rings seat properly into the head.

6) Check to be sure that the notch on the flow diverter lines up with the notch in the head.

7) Inspect the cover “o”-ring and replace if necessary.

8) Replace cover and tighten hex head screws until they are snug. Do not over-torque these screws. Do not interchange the inlet filter cover with the outlet filter cover. (The inlet filter has a “RF” prefix, the outlet filter has a “CF” prefix).

Trouble Shooting

Problem	Cause	Solution
Does not start.	ON/OFF switch. No electrical power. Defective motor.	Turn switch ON, replace switch if defective. Plug in cart. Replace.
No oil flow or erratic pump noise.	Filter housing not filled with oil. Suction leak. Defective pump.	Allow pump to run 30 to 60 seconds. Check tightness of inlet fittings. Check “o”-ring in inlet filter cover for nicks. Kink or restriction in inlet hose. Add 1 or 2 quarts of oil to inlet filter. Replace pump.
Indicator reads CHANGE or BYPASS.	Element dirty. Oil extremely cold or viscous.	Replace or clean elements (both filters). Change element to coarser micron rating.
Indicator does not seem to move.	No outlet element. 40 micron element installed in outlet filter.	Install element. Check cart model number to verify correct element. The inlet filter has a rating “RF” prefix; the outlet filter has a “CF” prefix.

Filter Cart Replacement Parts

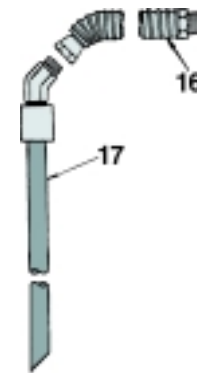
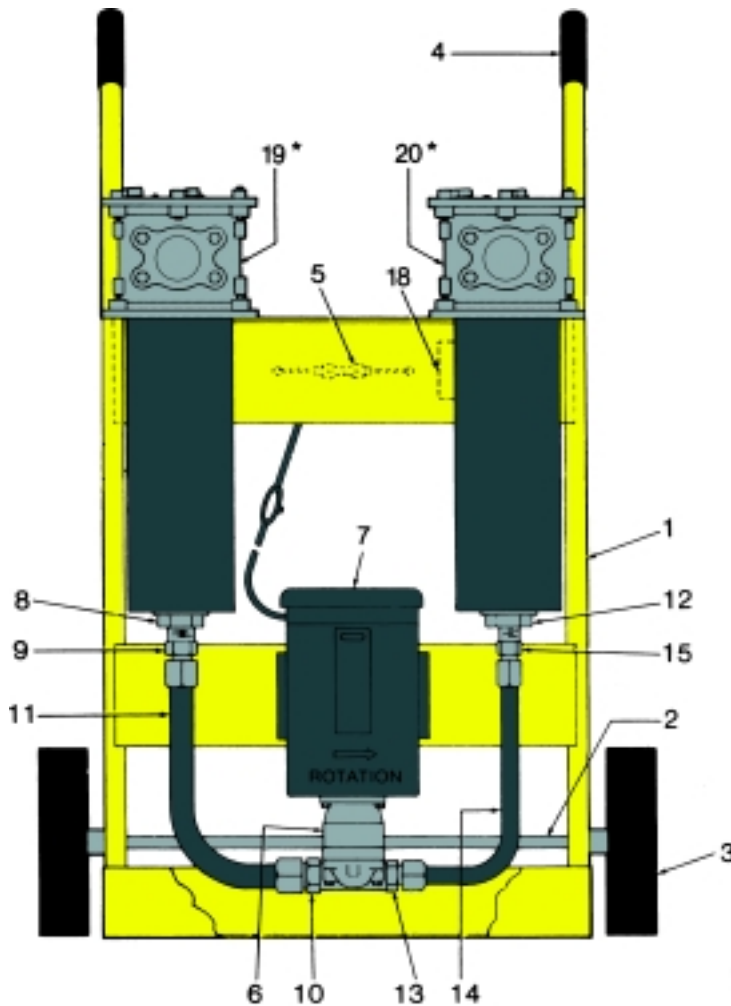

Replacement Element Part Numbers

Media Code	Buna Seals (Standard)	Fluorocarbon Seals
74W	924456	925043
40W	924455	925042
40SA	924448	925035
20C	924451	925038
10C	924450	925037
03C	924449	925036
20Q	933742Q	933743Q
10Q	924453Q	925040Q
05Q	924452Q	925039Q
02Q	933068Q	933069Q
WR	927584	928908

Item No.	Part No.	Description	Quantity	Item No.	Part No.	Description	Quantity
1	928690	Frame	1	12	928749	Pipe Reducer	1
2	928653	Axle	1	13	928729	Adapter Fitting	1
3	928650	Wheel	2	14	928676	Discharge Tube Assembly	1
4	928651	Handle Grip	2	15	928727	Tube Fitting	1
5	928649	Cord Cleat	1	16	928663	Hose Assy. - Buna N	2
Opt. 5	928623	Cord Reel	1	16	928621	Hose Assy. - Fluorocarbon	—
6	928731	Pump	1	17	928784	Tube Wand Assy. Buna N	2
7	928678	Motor 10MF	1	17	928620	Tube Wand Assy. Fluorocarbon	—
7	929692	Motor 5MF	—	18	932187	Name Plate	1
8	928748	Pipe Reducer	1	19*	RF2-1-**-PP3-YN-F9-1	Inlet Filter - Buna N	1
9	928728	Tube Fitting	1	19*	F3-RF2-1-**-PP3-YN-F9-1	Inlet Filter - Fluorocarbon	—
10	928652	Adapter Fitting	1	20*	CF2-1**-MP25-F9-YN-1	Outlet Filter - Buna N	1
11	928677	Suction Tube Assembly	1	20*	F3-CF2-1**-MP25-F9-YN-1	Outlet Filter - Fluorocarbon	—

**Refer to table above

5MF and 10MF

Portable Filter Cart

HOW TO ORDER:

Select the desired symbol (in the correct position) to construct a model code.

Example:

BOX 1	BOX 2	BOX 3	BOX 4	BOX 5	BOX 6
F3	10MF	40SA	10Q	6	Design number assigned by Parker

BOX 1: SEALS	
Symbol	Description
<i>None (Std.)</i>	Buna N (Nitrile)
F3	High temperature service

BOX 3 : INLET FILTER	
Symbol	Description
40SA	Synthetic
40W	Stainless Steel Mesh
74W	Stainless Steel Mesh
20C	Cellulose
20Q	Microglass III

BOX 5 : OPTIONS	
Symbol	Description
1	None
3	Magnets in inlet filter
6	20 FT electrical cord (retractable reel)
9	Indicator on inlet filter

BOX 2 : MODEL	
Symbol	Description
10MF	10 GPM (500 SUS MAX.)
5MF	5 GPM (3000 SUS MAX.)

BOX 4 : OUTLET FILTER	
Symbol	Description
10C	Cellulose
03C	Cellulose
20Q	Microglass III
10Q	Microglass III
05Q	Microglass III
02Q	Microglass III
WR	PAR-GEL™ Water Removal

BOX 6 : DESIGN NUMBER	
Symbol	Description
	Applied to the filter by Parker Hydraulic Filter Division. Use the full model code, including the design number when ordering replacement parts.

Please note the bolded options reflect standard options with a reduced lead-time. Consult factory on all other lead-time options.