

108 Series Hydraulic Power Units

*Pressures to 3500 psi
Flows to $\frac{3}{4}$ gpm*





108 Series Self-contained Hydraulic Power Units

Our compact 108 Series power units let you put the power where you need it. They're completely self-contained with an AC or DC motor, gear pump, reservoir, internal valving, load hold checks and relief valves.

The 108 Series models are designed for intermittent service and come in four standard pump sizes which produce flows of .0098, .0187, .0246, and .0321 cubic inches per revolution. Locking check valves are available in all models. Performance will vary with the type of fluid used. Several hydraulic circuits are available.

108 Series units are available with single- or bi-directional rotation. Single units are commonly used to charge accumulators, power one-direction hydraulic motors and cylinders, provide pilot flow to servo valves,

pressurize lube systems and supply multi-function circuits with external valving.

Bi-directional, reversible units operate double-acting cylinders and two-way motors.

We'd like to work with you on your special hydraulic applications. Our people know small hydraulics. We know how to design them, how to make them and how to apply them. Therefore, we can offer you a practical, economical solution to your fluid power problems.

Oildyne has pioneered top quality, compact hydraulic components since 1955. We can provide standard products or custom design high pressure, space saving solutions to your specific needs.

Typical applications

Positioning

- Hydraulic door operators
- Conveyor belt tensioners
- Medical chairs, beds, and equipment

Recreational Vehicles

- Leveling
- Slideouts
- Tent Trailers

Clamping

- Tool fixtures and jigs
- Hydraulic brakes
- Crimping tools
- Arbor presses
- Truck restraints

Cycling

- Garbage compactors
- Valve operators
- Press controls
- Packing equipment
- Indexing tables

Lifting

- Handicap lifts
- Scissor lift tables
- Pallet movers

Overall Dimensions

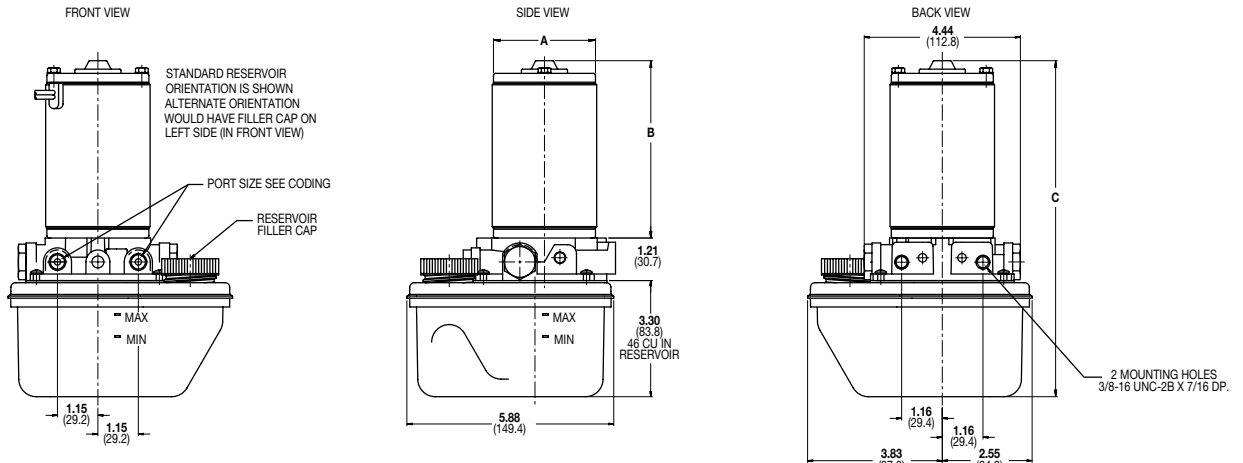

With Solenoid Valve

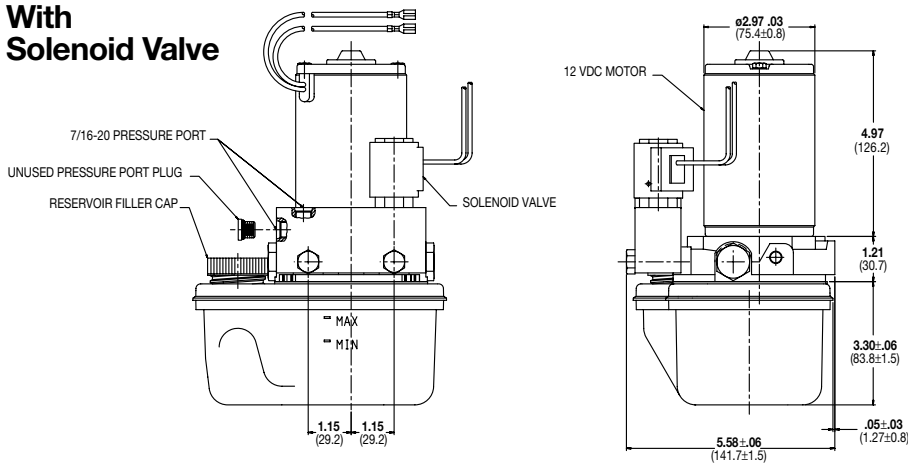

Motor Dimensions ± .050 (± 1.3)			
	A	B	C
AE/BE	2.97 (75.4)	4.97 (126.2)	9.50 (241.3)
AM/BI	3.77 (95.8)	5.96 (151.4)	10.49 (266.4)
IA	2.97 (75.4)	5.07 (128.8)	9.61 (244.1)
HA/HD	3.94 (100.1)	6.34 (161.0)	10.88 (276.4)

Note: All dimensions in inches (mm).

Reservoir Dimensions

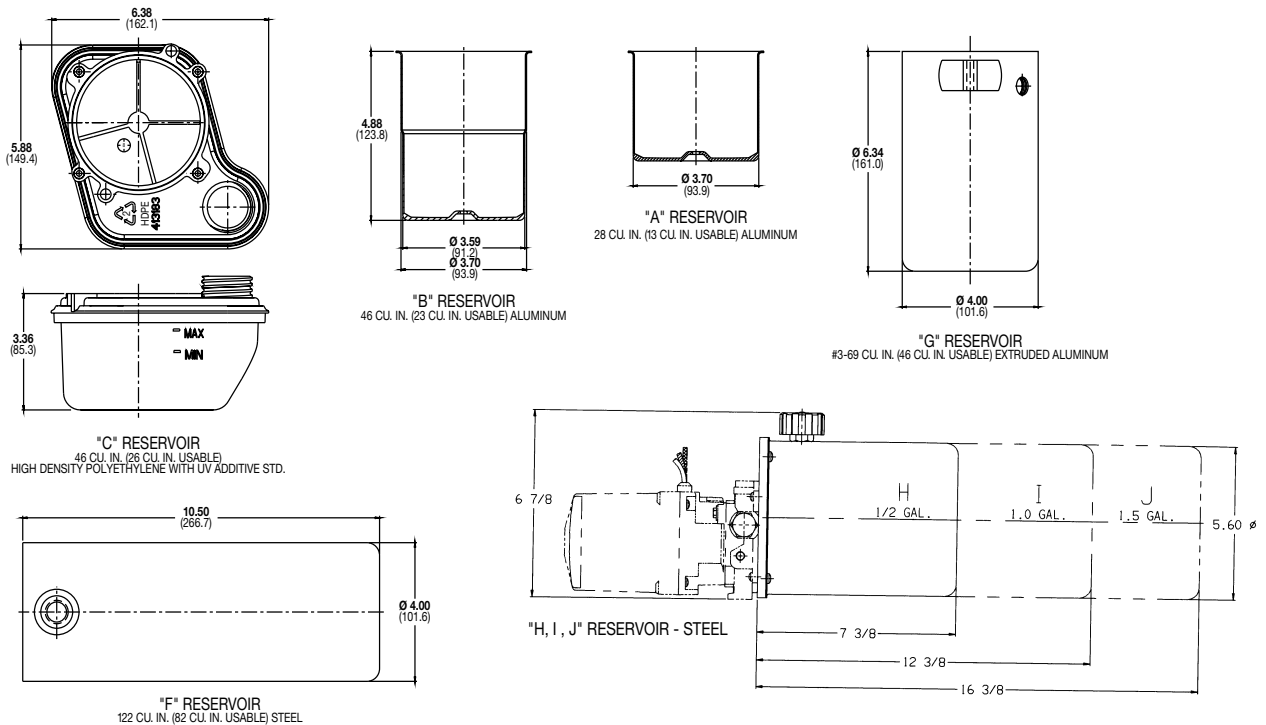

12 V DC Permanent Magnet Motor • Code AE • BE

Motor Type: AE and BE
 For intermittent duty cycles.



Wiring Diagram: AE • BE

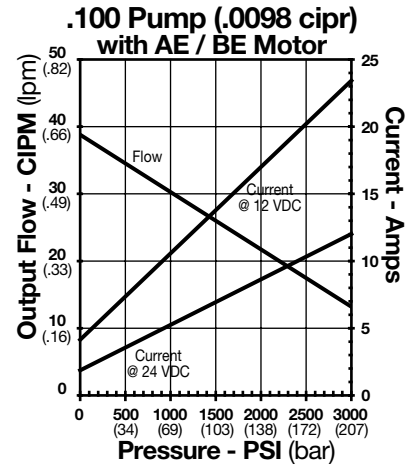
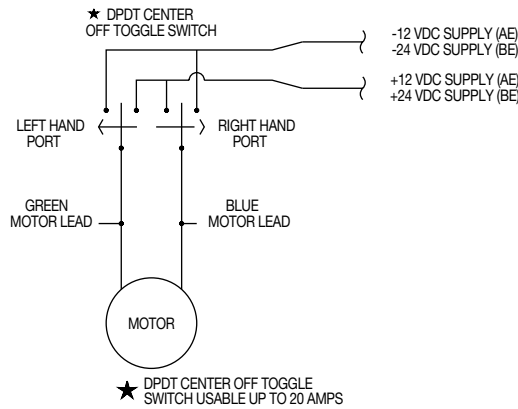

12 V DC Series Wound Motor • Code AM • BI

Motor Type: AM and BI
 For intermittent duty cycles.



Wiring Diagram: AM • BI

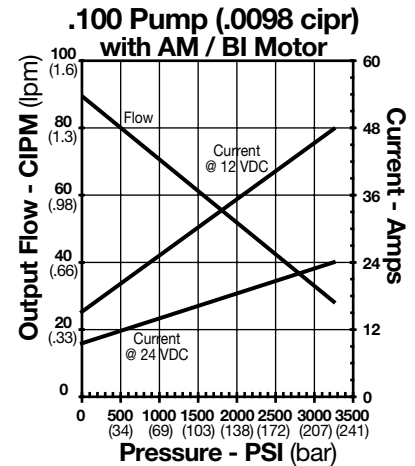
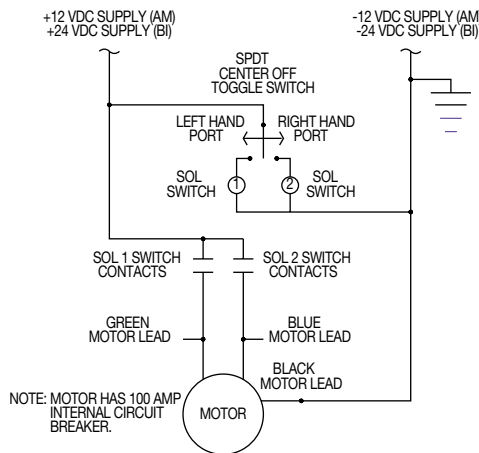

115/230 V AC Capacitor Start Motor • Code HA • HD

Motor Type: HA and HD
 Dual voltage 1/3 HP, 60/50 hz, 3450/2850 rpm, intermittent duty, single phase, open frame. Capacitor and relay included.



Wiring Diagram: HA

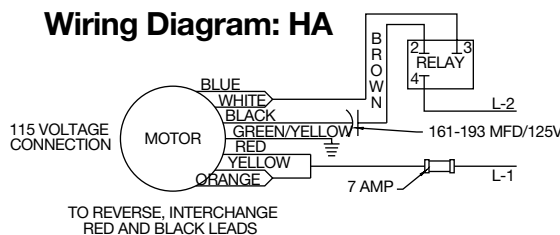

Wiring Diagram: HD

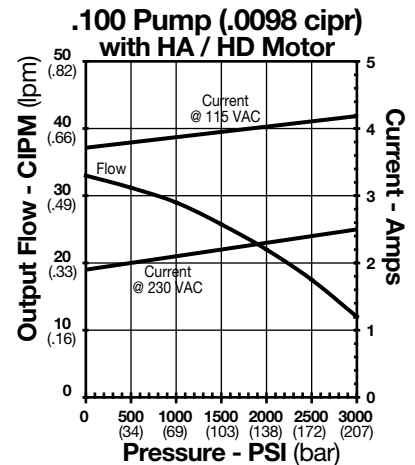
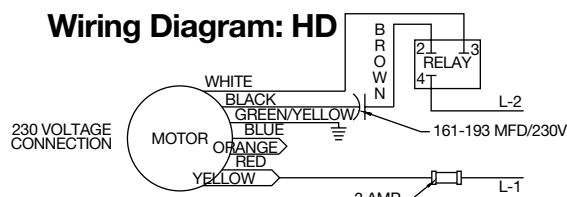

Note: 50 hz performance is 83% of curves shown.

Technical Information

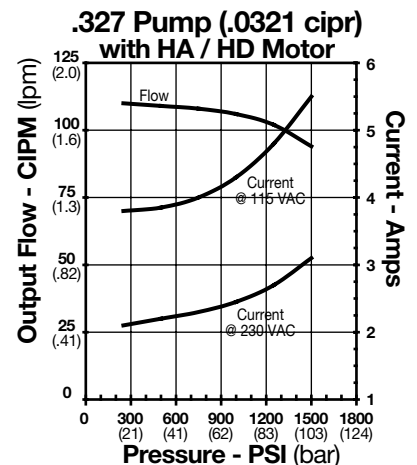
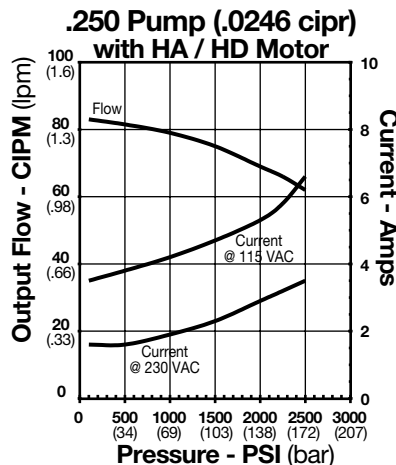
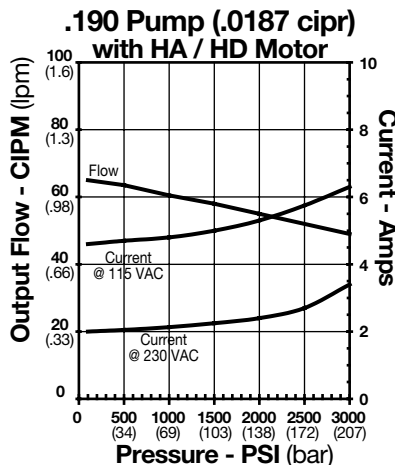
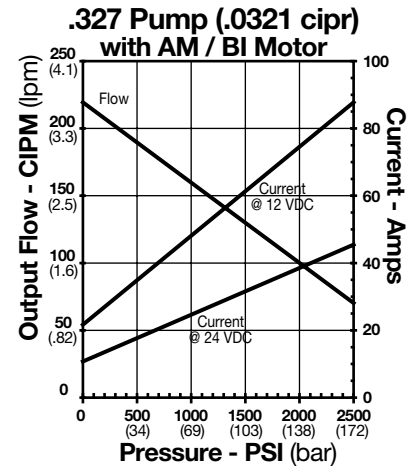
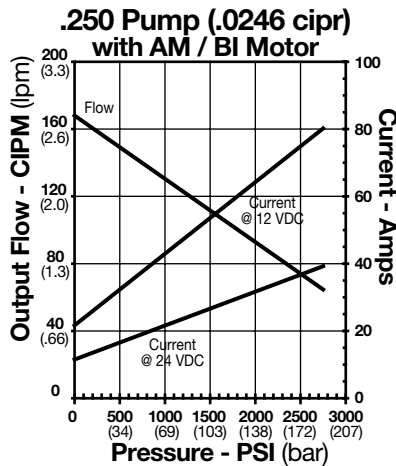
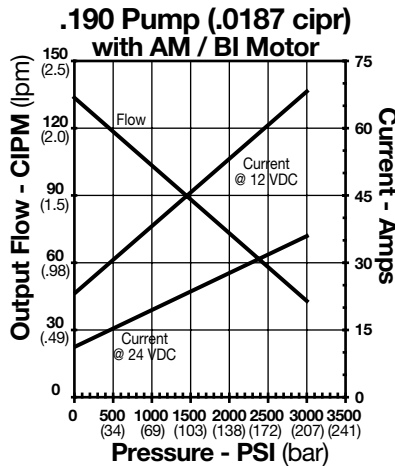
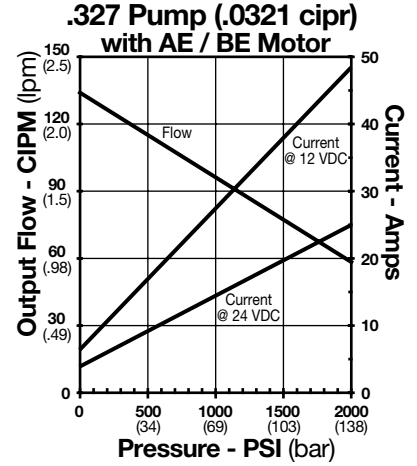
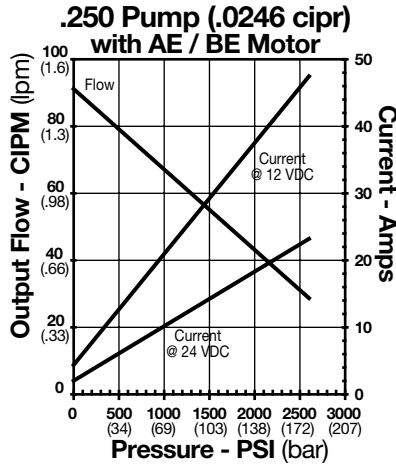
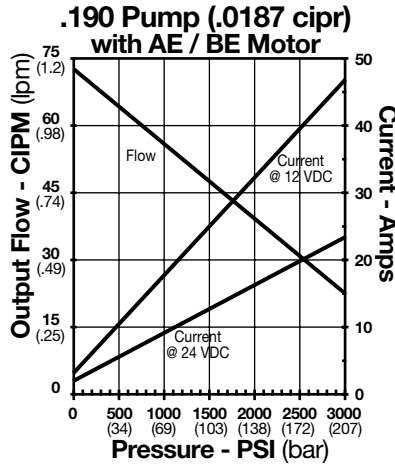

Note: Performance data is for reference only.

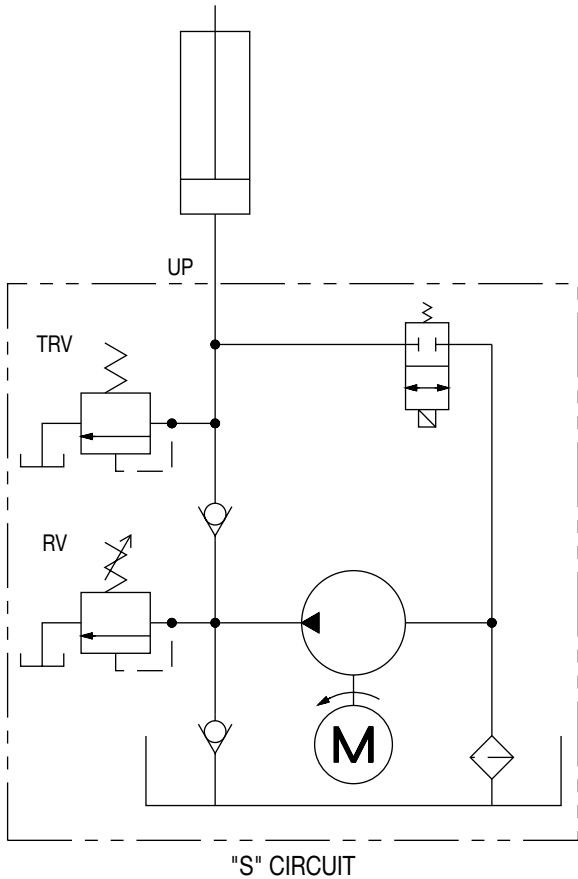
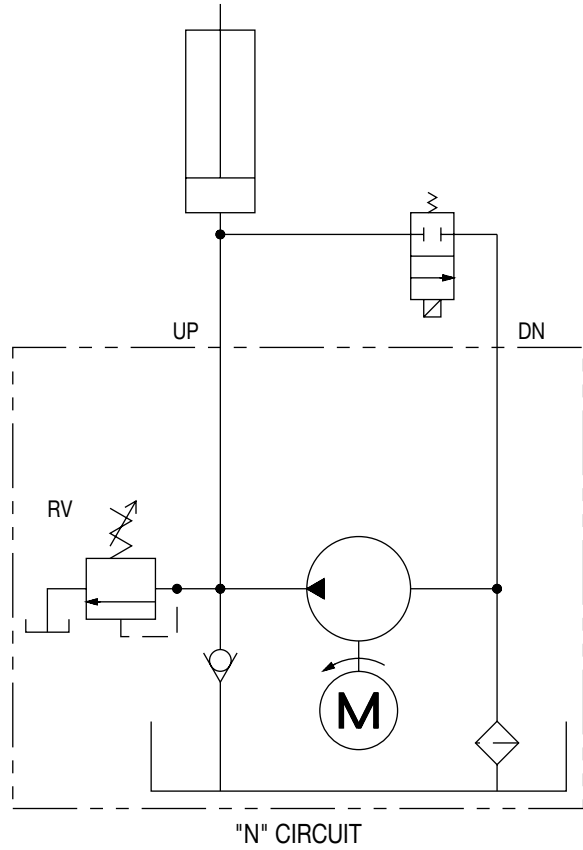
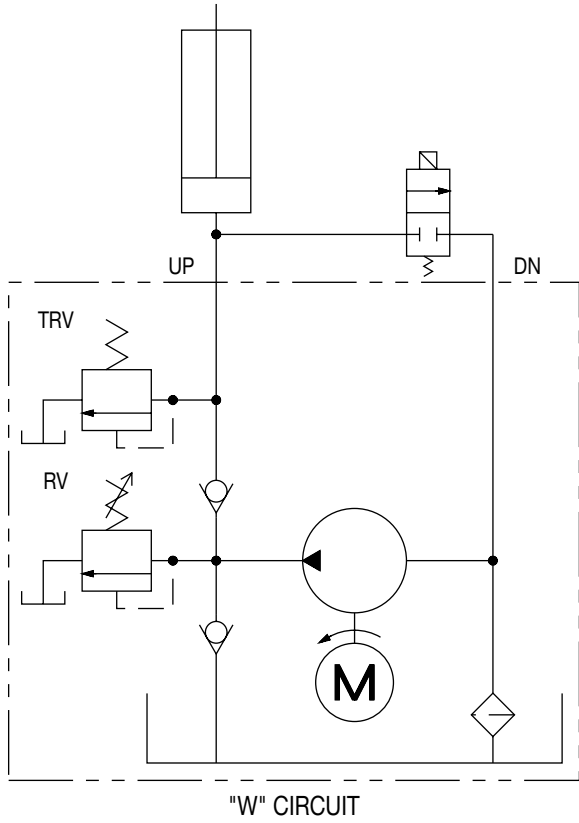

Thermal Relief Valves— Why?

The thermal relief valve's (TRV) purpose is to allow a bleed off of built up pressure due to thermal expansion of the fluid or to act as a (limited) shock load protection, should a cylinder in the system get bumped.

The thermal relief valve is included in circuits using a pilot operated check valve. The single direction units get one; the reversing units get two. It is located between the check valve and the 108 Series pump outlet port. It is a fixed relief valve with a pressure setting approximately 1500-2000 psi above the system relief valve pressure.

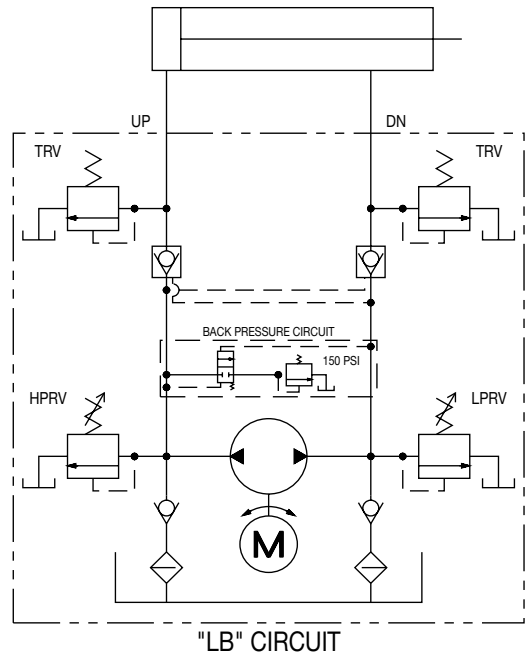
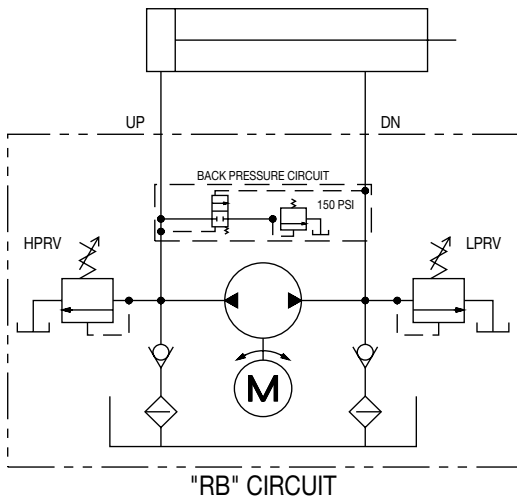
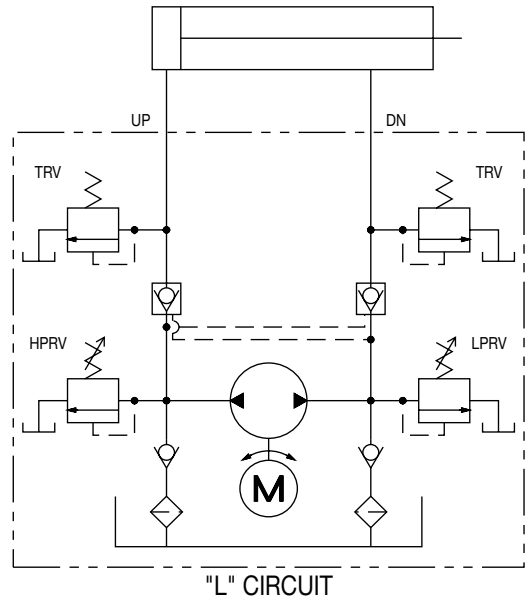
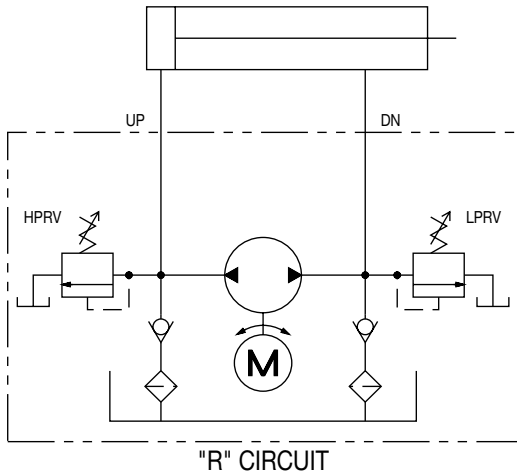

Back Pressure Circuits— Why?

The basic reversible circuit is essentially a closed loop. The oil returning from the system is fed back into the pump inlet. When a cylinder is being retracted more oil is being returned to the power unit than is leaving it due to the rod volume. This results in the DN side relief valve cracking open allowing the rod volume of oil to go back to the tank. The larger the rod volume the more open the relief valve will be. In many applications this is not a problem. However, if work is being done on the retract stroke, or if a pressure switch is used to signal the cylinder is fully retracted, the back pressure circuit is required. This circuit allows the rod volume of

oil to return to the reservoir through a special shuttle spool, before it reaches the pump. Full relief valve pressure is then available to retract the cylinder, also preventing a pressure switch from tripping before the full retract position is achieved.

Recommended uses:

- In systems where work is being done on the retract stroke
- Where a pressure switch is used to signal the full retract position
- In systems requiring a faster retract than extend speed

Standard Product Ordering Codes

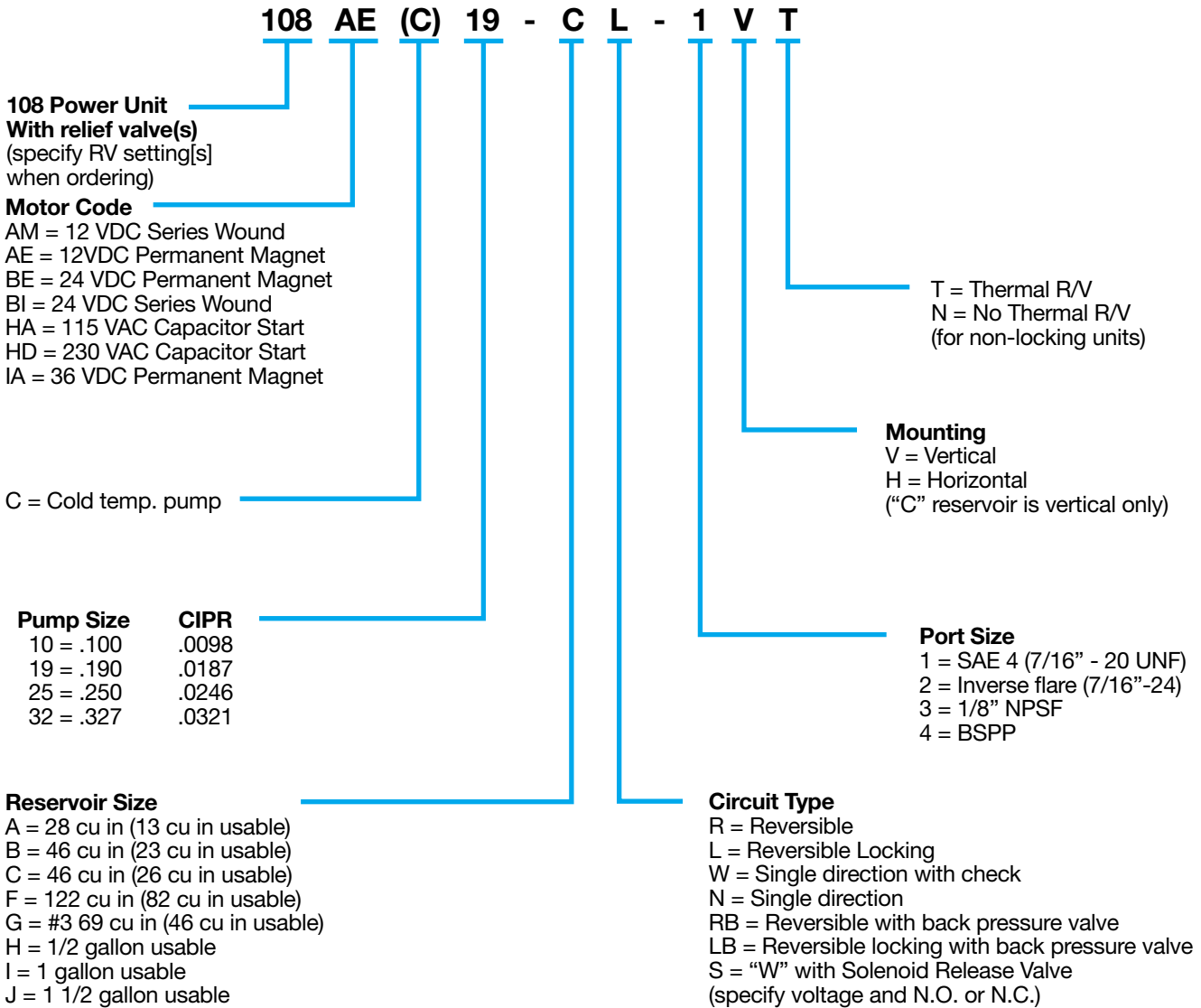

Hydraulic Fluid

ATF, OD18, or other clean hydraulic oil with a viscosity of 150 to 300 SUS at 100°F is acceptable. If another type of fluid is needed, please consult the factory.

Temperature Range

Normal operating range is +20°F to +140°F. Please review your application with the factory for uses below +20°F and over +140°F.